



420 N. Grove, Richardson, TX 75081
 Tele: (800) 527 - 4345 Fax: (800) 442 - 5263
 Web site: www.goindustries.com

Baja II Bumper Replacement

Installation Instructions

66621 (Black Finish)/ 67621 (UA Finish)

Ford Raptor 2017 - 2019

***** This bumper replacement is not intended for vehicles equipped with front parking sensors, adaptive cruise control, or adaptive power steering*****

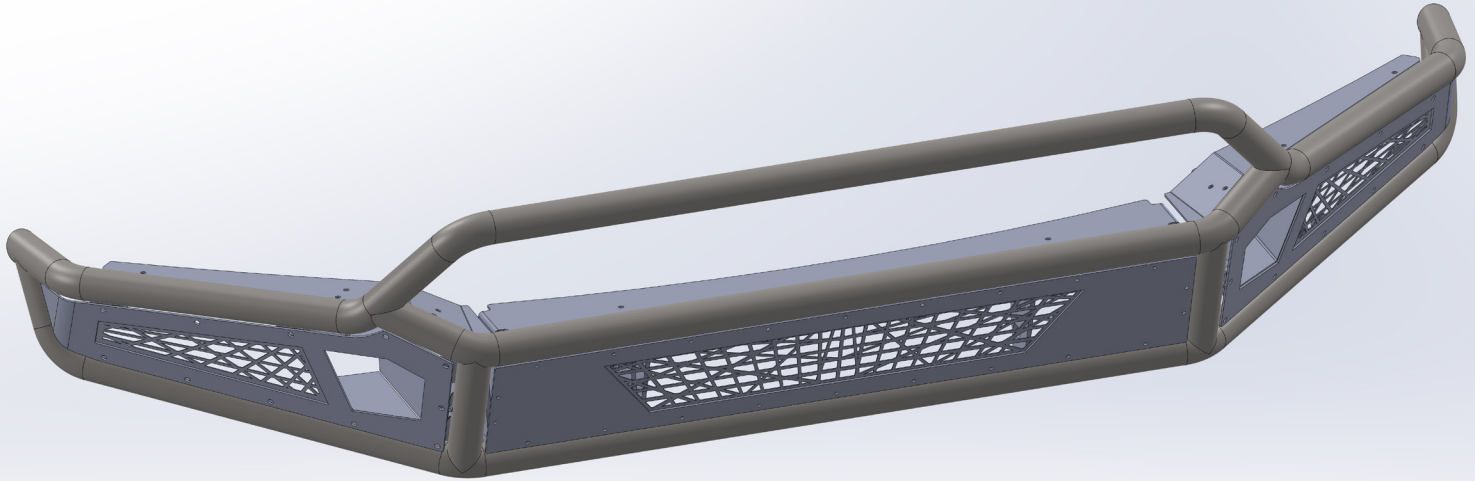

Note: Completely read instructions before beginning installation!

****Bumper replacement is HEAVY Team Lift recommended for safe installation****

Parts List:

- 1) 67621-1 Baja II Front Bumper
- 1) 66621-5 Bumper Mounting Bracket (Driver)
- 1) 66621-6 Bumper Mounting Bracket (Passenger)
- 1) 67621-2 Center Front Panel
- 1) 67621-3 Driver Front Panel
- 1) 67621-4 Passenger Front Panel
- 1) 67621-12 Center Top Cover Panel
- 1) 67621-13 Driver Top Cover Panel
- 1) 67621-14 Passenger Top Cover Panel
- 2) 66621-9 Top Cover Panel Bracket
- 1) 67621KIT Hardware Kit

67621KIT Hardware Kit Contents:

- 14) 1/2"-13 x 1 3/4" Hex Head Bolts Gr5 Zinc
- 32) 1/4"-20 x 1" Button Head Bolts Stainless Steel
- 24) 1/4"-20 x 3/4" Button Head Bolts Stainless Steel
- 6) 1/4"-20 x 1" Hex Head Bolts Gr5 Zinc
- 28) 1/2" Flat Washers Gr5 Zinc
- 62) 1/4" Flat Washers Gr5 Zinc
- 6) 1/4" Lock Washers Gr5 Zinc
- 14) 1/2"-13 Nylon Locking Nuts Gr5 Zinc
- 56) 1/4"-20 Nylon Locking Nut Gr5 Zinc

Extra hardware may be included



Baja II Bumper Replacement

Installation Instructions

66621 (Black Finish)/ 67621 (UA Finish)

Ford Raptor 2017 - 2019

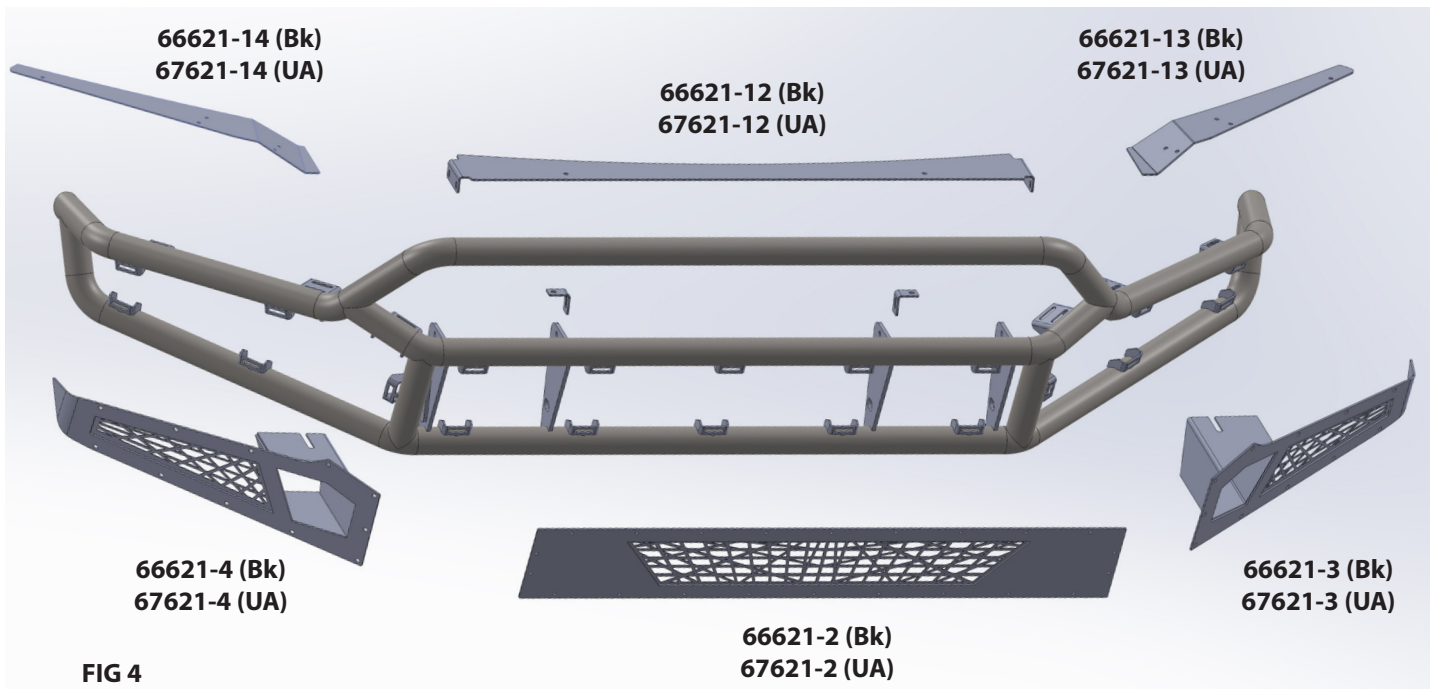
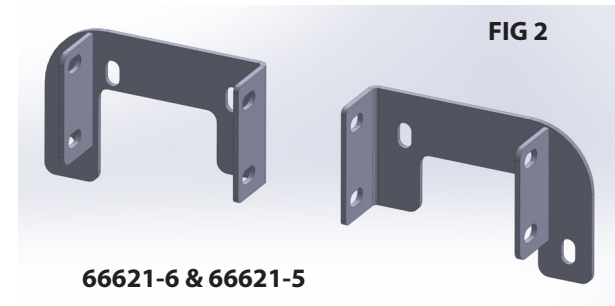
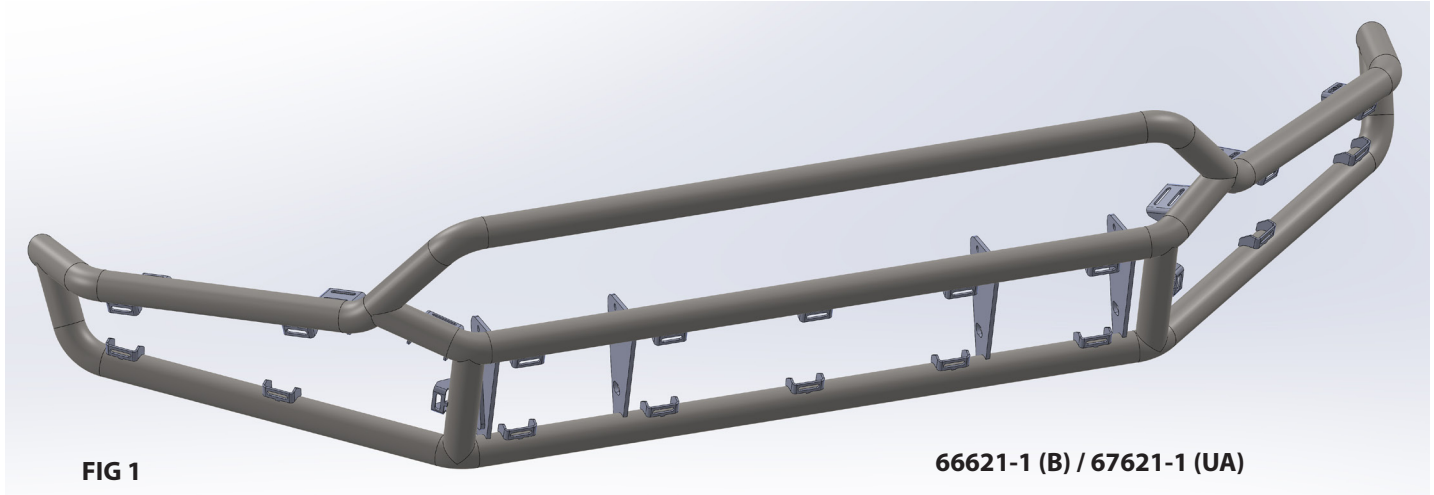

Baja II Bumper Replacement

Installation Instructions

66621 (Black Finish)/ 67621 (UA Finish)

Ford Raptor 2017 - 2019

- 1) Remove the contents from the box and check for missing pieces or damage. If parts are missing or damaged, contact the original place of purchase. Two people are strongly recommended for this install.
- 2) Remove the factory skid plate and spacer bar from the vehicle and set aside for re-installation later on.
- 3) Remove the plastic insert from the center of the bumper (The panel retention clips can be difficult to access from the backside of the bumper so you may need to remove the center panel by pulling it away from the front of the bumper. The panel edges can be VERY sharp, so care should be taken not to use too much force which could result in injury or damage to vehicle components.)
- 4) Remove the small mounting bolts from the lower radiator side of the small bumper support struts that are attached to the factory bumper. These will not be reused.
- 5) Remove the lower rear mounting nut from the backside of the factory bumper on both sides.
- 6) Remove the two front mounting nuts per side from the front of the factory bumper. These are accessible through the space covered by the previously removed plastic insert in the front bumper.
- 7) Separate any wiring looms or molding clips that are still attached to the factory front bumper, and carefully remove the factory bumper from the vehicle.
- 8) Remove the factory bumper mounting hardware studs from the bumper mounting plates of the frame as they will not be reused.
- 9) Secure any wiring looms that are loose.
- 10) You may remove the intercooler shroud altogether, or leave it installed whichever you prefer. If you choose to leave the shroud installed, it will need to be trimmed to fit against the front cover plate once the bumper is installed so that it does not deform and impede airflow.
- 11) Locate the 66621-5 (Driver) and 66621-6 (Passenger) brackets (See FIG 2), and secure the brackets to the bumper mounting plates on the frame utilizing (6) ½"-13 x 1 ¾" Hex Head Bolts, (12) ½" Flat Washers, and (6) ½"-13 Nylon Locking Nuts. Hardware should be snug but still allowing for adjustment once the new bumper is installed.
- 12) Lift the bumper into place with the brackets oriented as shown in FIG 5, and loosely install to the mounting brackets using (8) ½"-13 x 1 ¾" Hex Head Bolts, (16) ½" Flat Washers, (8) ½"-13 Nylon Locking Nuts.

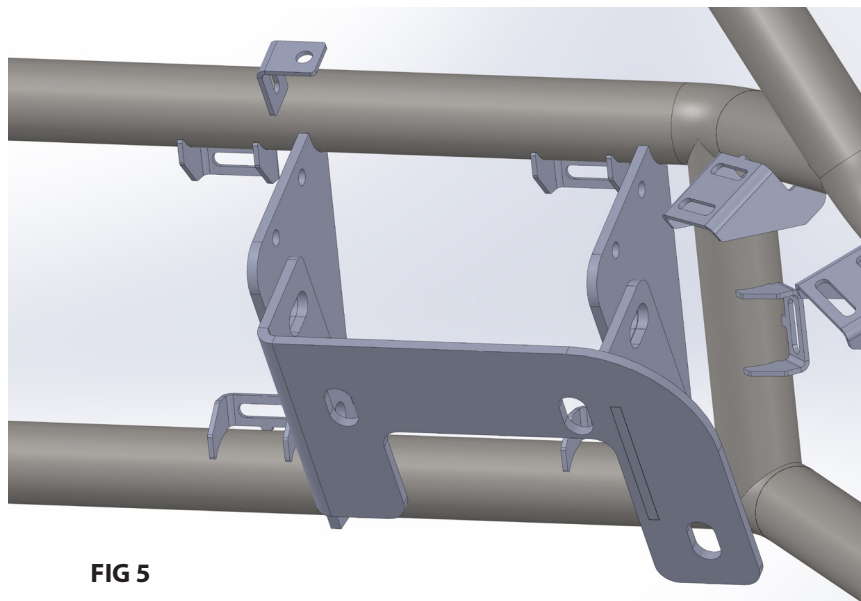

FIG 5

Baja II Bumper Replacement

Installation Instructions

66621 (Black Finish)/ 67621 (UA Finish)

Ford Raptor 2017 - 2019

- 13) Adjust the bumper so that it is centered and level around the front body panels with a minimal gap between the main tube and the body work. The ends of the bumper should be roughly even with the wheel well edge at the bottom of the front fenders.

!!! THE TUBE SHOULD NOT BE CLOSER TO THE FRONT TIRE THAN THE WHEEL WELL LIP AS THIS COULD CAUSE VEHICLE AND/OR TIRE DAMAGE !!!

- 14) Once completely adjusted, tighten all ½" mounting hardware to appropriate levels (approximately 75 ft lbs.)
- 15) Some of the holes in the cover panels of the bumper are purely cosmetic. FIGs 6, 7 & 8 highlight which holes are cosmetic and will have hardware installed in them previous to panel installation on the bumper. Each of these holes will require (1) ¼"-20 x ¾" Button Head Cap Screw from the outside, and (1) ¼" Flat Washer with a (1) ¼"-20 Nylon Locking Nut on the back side of the panel.

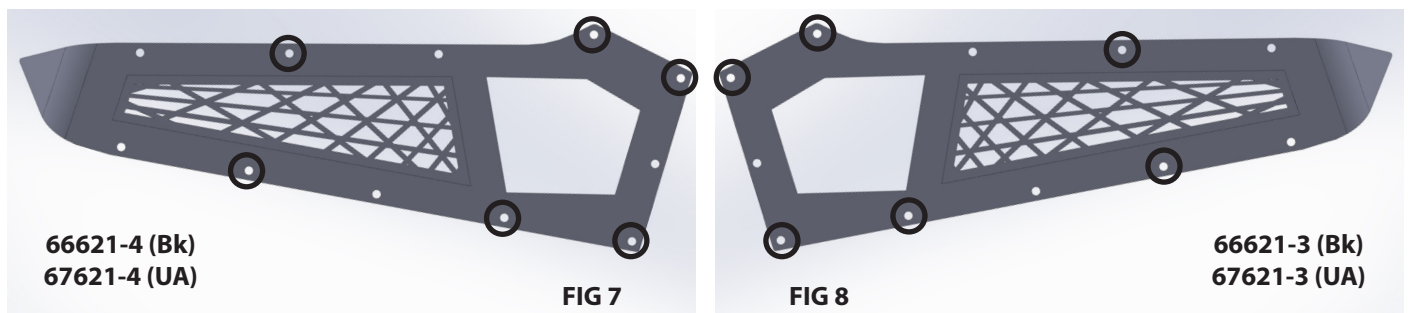
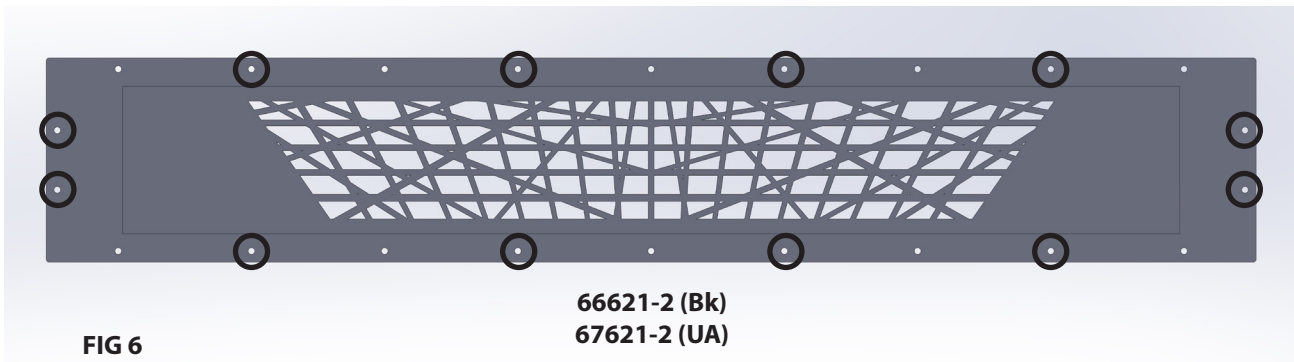

- 16) Install the (2) 66621-9 top cover panel brackets as shown in FIG 3, using (1) ¼"-20 x 1" Hex Head Bolt, (1) ¼" Lock Washer, and (1) ¼" Flat Washer to secure each bracket to the bumper.
- 17) Begin to attach all of the cover panels using the ¼"-20 x 1" Button Head Cap Screws from the outside, with (1) ¼" Flat Washer with a (1) ¼"-20 Nylon Locking Nut on the back side of each welded panel mounting tab. See FIG 4
- 18) The top center cover panel will also use (4) ¼"-20 x 1" Hex Head Bolts, (4) ¼" Lock Washers, and (4) ¼" Flat Washers to secure the panel ends to the main bumper structure.
- 19) Once all cover panels are installed, you may wire up any aftermarket lights for the bumper adhering to the light manufacturers' instructions.
- 20) You may now re-install your factory skid plate and spacer to complete your installation.

Note: Re-check all hardware for proper tightness upon completion and periodically inspect hardware and parts for signs of wear throughout the life of the product.



420 N. Grove, Richardson, TX 75081
Tele: (800) 527 - 4345 Fax: (800) 442 - 5263
Web site: www.goindustries.com

Baja II Bumper Replacement

Installation Instructions

66621 (Black Finish)/ 67621 (UA Finish)

Ford Raptor 2017 - 2019

